

# ABSOLUTE, DIFFERENTIAL AND GAUGE PRESSURE TRANSMITTER FOR REMOTE SEAL(S)

DATA SHEET

FKB, FKD, FKM

The FCX-AII series absolute, differential and gauge pressure transmitters accurately measures and transmits proportional 4 to 20mA signal. The transmitters utilize the unique micromachined capacitive silicon sensor with state-of-the-art microprocessor technology to provide exceptional performance and functionality.

## FEATURES

### 1. High accuracy

0.065 % accuracy is a standard feature for differential and gauge pressure models and 0.2% accuracy for absolute pressure models.

The microcapacitance silicon sensor assures this feature for all elevated or suppressed calibration ranges without additional adjustment.

### 2. Minimum environmental influence

The "Advanced Floating Cell" design which protects the pressure sensor against changes in temperature, and over-pressure substantially reduces total measurement error in actual field applications.

### 3. Fuji/HART® bilingual communications protocol

FCX-AII series transmitter offers bilingual communications to speak both Fuji proprietary protocol and HART®. Any HART® compatible devices can communicate with FCX-AII.

### 4. Application flexibility

Various options that render the FCX-AII suitable for almost any process applications include:

- Full range of hazardous area approvals
- Built-in RFI filter and lightning arrester
- 5-digit LCD meter with engineering unit
- Stainless steel electronics housing
- Wide selection of materials
- High temperature, high vacuum seals

### 5. Burnout current flexibility (Under Scale: 3.2 to 4.0mA, Over Scale: 20.0 to 22.5mA)

Burnout signal level is adjustable using Model FXW Hand Held Communicator (HHC) to comply with NAMUR NE43.

### 6. Dry calibration without reference pressure

Thanks to the best combination of unique construction of mechanical parts (Sensor unit) and high performance electronics circuit (Electronics unit), reliability of dry calibration without reference pressure is at equal level as wet calibration.



## SPECIFICATIONS

### Functional specifications

#### Type:

- FKD : differential pressure transmitter with remote seal(s)
- FKB : gauge pressure transmitter with remote seal
- FKM : absolute pressure transmitter with remote seal

#### Service:

Liquid, gas, or vapour

#### Span, range, and overrange limit:

Model	Span limits		Range limits
	Minimum	Maximum	
<b>FKD</b>			
	(mbar)	(mbar)	(mbar)
F□D□□3	3.2	320	± 320
F□D□□5	13	1300	± 1300
F□D□□6	50	5000	± 5000
F□D□□8	300	30000	± 30000
<b>FKB</b>			
	(bar)	(bar)	(bar)
F□B□□1	0,013	1,3	-1 to +1,3
F□B□□2	0,05	5	-1 to +5
F□B□□3	0,3	30	-1 to +30
F□B□□4	1	100	-1 to +100
F□B□□5	5	500	-1 to +500
<b>FkM</b>			
	(abs bar)	(abs bar)	(abs bar)
F□M□□1	0,016	0,16	0 to +0,16
F□M□□2	0,016	1,3	0 to +1,3
F□M□□3	0,05	5	0 to +5
F□M□□4	0,3	30	0 to +30

Remark: To minimize environmental influence, span should be greater than 1/40 of the max. span in most applications.

**Output signal:**

4 to 20mA DC with digital signal superimposed on the 4 to 20mA signal.

**Power supply:**

Transmitter operates on 10.5V to 45V DC at transmitter terminals.

10.5V to 32V DC for the units with optional arrester.

**Load limitations:** see figure below

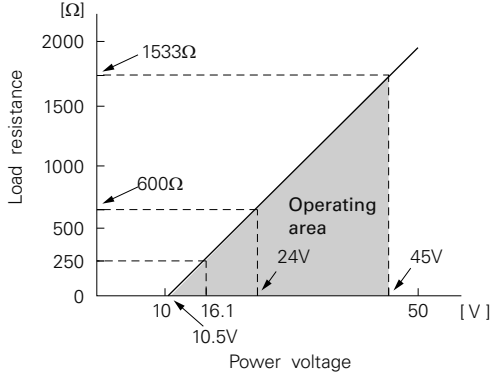

Note: For communication with HHC<sup>(1)</sup> min. of 250Ω is required.

**Hazardous locations:**

Authority (Digit 10=)	Intrinsic safety																					
ATEX (K)	Ex II 1 G Ex ia IIC T5 (-40°C ≤ Ta ≤ +50 °C) Ex ia IIC T4 (-40°C ≤ Ta ≤ +70 °C) IP66/67 Entity Parameters: Ui ≤ 28 Vdc, li ≤ 94.3 mA, Pi ≤ 0.66 W Ci = 36 nF/26 nF for models with/without Arrester Li = 0.7 mH/0.6 mH for models with/without Analog Indicator																					
Factory Mutual (pending) (H)	Class I II III Div.1 Groups A, B, C, D, E, F, G T4 Entity Type 4X <table border="1"> <thead> <tr> <th colspan="2">Model code</th> <th>Tamb</th> </tr> <tr> <th>9th digit</th> <th>13th digit</th> <th></th> </tr> </thead> <tbody> <tr> <td>A,B,C,D,J</td> <td>Y,G,N</td> <td>-40°C to +85°C</td> </tr> <tr> <td>L,P,M,1,2,3</td> <td>Y,G,N</td> <td>-20°C to +80°C</td> </tr> <tr> <td>Q,S,N,4,5,6</td> <td>Y,G,N</td> <td>-20°C to +60°C</td> </tr> <tr> <td>E,F,G,H,K</td> <td>Y,G,N</td> <td>-40°C to +60°C</td> </tr> <tr> <td>-</td> <td>W,A,D</td> <td>-10°C to +60°C</td> </tr> </tbody> </table> Entity Parameters: Vmax=42.4V, Imax=113mA, Pi=1W, Ci=35.98nF, Li=0.694mH	Model code		Tamb	9th digit	13th digit		A,B,C,D,J	Y,G,N	-40°C to +85°C	L,P,M,1,2,3	Y,G,N	-20°C to +80°C	Q,S,N,4,5,6	Y,G,N	-20°C to +60°C	E,F,G,H,K	Y,G,N	-40°C to +60°C	-	W,A,D	-10°C to +60°C
Model code		Tamb																				
9th digit	13th digit																					
A,B,C,D,J	Y,G,N	-40°C to +85°C																				
L,P,M,1,2,3	Y,G,N	-20°C to +80°C																				
Q,S,N,4,5,6	Y,G,N	-20°C to +60°C																				
E,F,G,H,K	Y,G,N	-40°C to +60°C																				
-	W,A,D	-10°C to +60°C																				
CSA (J)	Ex ia Class I, Groups A, B, C and D; Class II, Groups E,F and G; Class III Per drawing TC 522873 Temp. code T5 for Tamb max = +50°C Temp. code T4 for Tamb max = +70°C Entity Parameters: Vmax = 28 Vdc, Imax = 94.3 mA, Pmax = 0.66 W Ci = 36 nF/25 nF for models with/without Arrester Li = 0.7 mH/0.6 mH for models with/without Analog Indicator																					
IECEX (T)	Ex ia IIC T5 (-40°C ≤ Ta ≤ +50 °C) Ex ia IIC T4 (-40°C ≤ Ta ≤ +70 °C) IP66/67 Entity Parameters: Ui ≤ 28 Vdc, li ≤ 94.3 mA, Pi ≤ 0.66 W Ci = 36 nF/25 nF for models with/without Arrester Li = 0.7 mH/0.6 mH for models with/without Analog Indicator																					

Authority	Flameproof
ATEX (X)	Ex II 2 GD Ex d IIC T6 (-40°C ≤ Ta ≤ +65 °C) Ex d IIC T5 (-40°C ≤ Ta ≤ +85 °C) Ex tD A21 IP66/67 T 85°C Ex tD A21 IP66/67 T 100°C Electrical ratings Model Without arrester: Ui ≤ 45 Vdc, 4-20 mA loop powered, Pi ≤ 1.0125 W Model With arrester: Ui ≤ 32 Vdc, 4-20 mA loop powered, Pi ≤ 1.0125 W
Factory Mutual (pending) (D)	Class I Div.1 Groups B, C, D T6 Type 4X Class II III Div.1 Groups E, F, G T6 Type 4X Tamb max = +60°C
CSA (E)	Class I, Groups C and D; Class II, Groups E,F and G ; Class III Maximum ambient temperature 85°C Maximum working pressure 50 Mpa Electrical ratings Model Without arrester: Ui ≤ 45 Vdc, 4-20 mA Model With arrester: Ui ≤ 32 Vdc, 4-20 mA Note: "Seal not required"
IECEX (R)	Ex d IIC T6 (-40°C ≤ Ta ≤ +65 °C) Ex d IIC T5 (-40°C ≤ Ta ≤ +85 °C) DIP A21 IP66/67 T 85°C DIP A21 IP66/67 T 100°C Electrical ratings Model Without arrester: Ui ≤ 45 Vdc, 4-20 mA loop powered, Pi ≤ 1.0125 W Model With arrester: Ui ≤ 32 Vdc, 4-20 mA loop powered, Pi ≤ 1.0125 W

Authority (Digit 10=)	Type n Nonincendive																					
ATEX (P)	Ex II 3 G Ex nA II T5 (-40°C ≤ Ta ≤ +70 °C) IP66/67 Electrical ratings Model Without arrester: Ui ≤ 45 Vdc, 4-20 mA loop powered, Pi ≤ 1.0125 W Model With arrester: Ui ≤ 32 Vdc, 4-20 mA loop powered, Pi ≤ 1.0125 W Optional Analog indicator is not available for type "n"																					
Factory Mutual (pending) (H)	Class I II III Div.2 Groups A, B, C, D, F, G T4 Entity Type 4X <table border="1"> <thead> <tr> <th colspan="2">Model code</th> <th>Tamb</th> </tr> <tr> <th>9th digit</th> <th>13th digit</th> <th></th> </tr> </thead> <tbody> <tr> <td>A,B,C,D,J</td> <td>Y,G,N</td> <td>-40°C to +85°C</td> </tr> <tr> <td>L,P,M,1,2,3</td> <td>Y,G,N</td> <td>-20°C to +80°C</td> </tr> <tr> <td>Q,S,N,4,5,6</td> <td>Y,G,N</td> <td>-20°C to +60°C</td> </tr> <tr> <td>E,F,G,H,K</td> <td>Y,G,N</td> <td>-40°C to +60°C</td> </tr> <tr> <td>-</td> <td>W,A,D</td> <td>-10°C to +60°C</td> </tr> </tbody> </table>	Model code		Tamb	9th digit	13th digit		A,B,C,D,J	Y,G,N	-40°C to +85°C	L,P,M,1,2,3	Y,G,N	-20°C to +80°C	Q,S,N,4,5,6	Y,G,N	-20°C to +60°C	E,F,G,H,K	Y,G,N	-40°C to +60°C	-	W,A,D	-10°C to +60°C
Model code		Tamb																				
9th digit	13th digit																					
A,B,C,D,J	Y,G,N	-40°C to +85°C																				
L,P,M,1,2,3	Y,G,N	-20°C to +80°C																				
Q,S,N,4,5,6	Y,G,N	-20°C to +60°C																				
E,F,G,H,K	Y,G,N	-40°C to +60°C																				
-	W,A,D	-10°C to +60°C																				
CSA (J)	Class I Div.2 Groups A, B, C, D Class II Div.2 Groups E, F, G Class III Div.2 Temp Code T5 Tamb max = +50°C Temp Code T4 Tamb max = +70°C Entity Parameters: Vmax = 28 Vdc, Imax = 94.3 mA, Pmax = 0.66 W Ci = 36 nF/25 nF for models with/without Arrester Li = 0.7 mH/0.6 mH for models with/without Analog Indicator																					
IECEX (Q)	Ex nA II T5 (-40°C ≤ Ta ≤ +70 °C) IP66/67 Electrical ratings Model Without arrester: Ui ≤ 45 Vdc, 4-20 mA loop powered, Pi ≤ 1.0125 W Model With arrester: Ui ≤ 32 Vdc, 4-20 mA loop powered, Pi ≤ 1.0125 W Optional Analog indicator is not available for type "n"																					

**Zero/span adjustment:**

Zero and span are adjustable from the HHC<sup>(1)</sup>. Zero and span are also adjustable externally from the adjustment screw.

**Damping:**

Adjustable from HHC or local adjustment unit with LCD display.

The time constant is adjustable between 0 to 32 sec

**Zero elevation/suppression:**

Zero can be elevated or suppressed within the specified range limit of each sensor model.

**Normal/reverse action:**

Selectable from HHC<sup>(1)</sup>.

**Indication:**

Analog indicator or 5-digit LCD meter, as specified.

**Burnout direction:** Selectable from HHC<sup>(1)</sup>

If self-diagnostic detect transmitter failure, the analog signal will be driven to either "Output Hold", "Output Overscale" or "Output Underscale" modes.

"Output Hold":

Output signal is hold as the value just before failure happens.

"Output Overscale":

Adjustable within the range 20.0mA to 22.5mA from HHC<sup>(1)</sup>

"Output Underscale":

Adjustable within the range 3.2mA to 4.0mA from HHC<sup>(1)</sup>

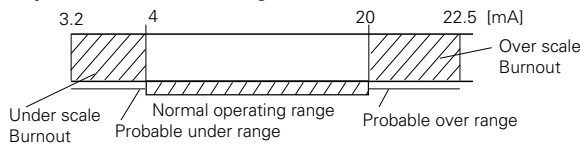

Output Limits conforming the NAMUR NE43 by order.

**Loop-check output:**

Transmitter can be configured to provide constant signal 3.2mA through 22.5mA by HHC<sup>(1)</sup>.

**Temperature limit:**

Ambient: -40 to +85°C

-20 to +80°C (for LCD indicator)

-40 to +60°C (for arvester option)

-10 to +60°C (for fluorinated oil fill transmitter)

-10 to +85°C (for silicone oil, code "H", "S", "K")

+20 to +85°C (for silicone oil, code "J", "T")

For explosionproof units (flameproof or intrinsic safety), ambient temperature must be within the limits specified by each standard.

Process: Check in the seal - datasheet with the specific temperature conditions.

Storage: -40 to +90°C

**Humidity limit:**

0 to 100% RH

**Communication:**

With HHC<sup>(1)</sup> (model FXW, consult DS No.EDS8-47), following items can be remotely displayed or configured.

Note:

HHC's version must be higher than 7.0 (or FXW □□□□ 1-□4), for FCX -All for supporting these items: "Saturate current", "Write protect".

Items	Fuji Protocol with FXW		Hart Protocol	
	Display	Set	Display	Set
Tag No.	v	v	v	v
Model No.	v	v	—	—
Serial No. & Software Version	v	—	v	—
Engineering unit	v	v	v	v
Range limit	v	—	v	—

Measuring range	v	v	v	v
Damping	v	v	v	v
Output mode	Linear	v	v	v
	Square root	v	v	v
Burnout direction	v	v	v	v
Calibration	v	v	v	v
Output adjust	—	v	—	v
Data	v	—	v	—
Self diagnoses	v	—	v	—
Printer (In case of FXW with printer option)	v	—	—	—
External switch lock	v	v	v	v
Transmitter display	v	v	v	v
Linearize*	v	v	—	—
Rerange	v	v	v	v
Saturate current	v	v	v	v
Write protect	v	v	v	v
History				
- Calibration history	v	v	v	v
- Ambient temperature history	v	—	v	—

(Note) (1) HHC: Hand Held Communicator

**\*Local configurator with LCD display (option):**

Local configurator with 3 push button and LCD display can support all items (Fuji Protocol list) except "Linearize" function.

**Programmable output linearization function:**

Output signal can be characterized with "14 points linear approximation function" from HHC<sup>(1)</sup>.

**Performance specifications**

Reference conditions, silicone oil fill, 316SS isolating diaphragms, 4 to 20mA analog output.

**Accuracy rating:**

(including linearity, hysteresis, and repeatability)

For span greater than 1/10 of URL :

±0,065 % of calibrated span for F#B, F#D

±0,2 % of calibrated span for F#M

For span smaller than 1/10 of URL :

±(0,02 + 0,05 x 0,1x URL/span) % of span (F#B, F#D)

±(0,05+0,05 x 0,1x URL/span) % of span (F#M)

**Stability:**

±0.2% of upper range limit (URL) for 10 years.

**Linearity :**

0,05% of calibrated span (F#B, F#D)

0,1% of calibrated span (F#M)

**Temperature effect:**

Effect per 28°C change between -40°C and +85°C

Model F#M :

Zero shift : ±(0,125 +0,1URL/span) % of URL

Total effect : ±(0,125 +0,1URL/span) % of URL

Model F#B, F#D :

Zero shift : ±(0,1+0,025%URL/span) % of URL

Total effect : ±(0,125 +0,025URL/span) % of URL

**Static pressure effect (F#D) :**

Zero shift : ± 0,05% of URL for 100 bar

Span shift : -0,2% of URL for 100 bar

**Overrange effect (F#B, F#M) :**

Zero shift : 0,2% of URL, for any overrange pressures (limited to the max. overrange pressure)

**Overrange effect (F#D) :**

Zero shift : ±0,3% of URL / 100 barlimit

**Supply voltage effect:**

Less than 0.005% of calibrated span per 1V

**RFI effect :**

< 0,2% of URL for the frequencies of 20 to 1000 MHz and field strength of 10 V/m when electronic housing covers are on (Classification : 2-abc : 0,2% of span according SAMA PMC 33.1)

**Update rate:** 60 msec

**Response time :** (at 63,2% of output signal)

Time constant : 300 msec (F#D span code "3")  
 Time constant : 200 msec (other spans and F#B, F#M)  
 Dead time : 300 msec  
 Response time = time constant + dead time

**Mounting position effect :**

Zero shift : < 12 mm WC for 10° incline in any position. This shift can be corrected with the zero adjustment.  
 This effect is doubled for fluorinated oil filling.  
 No influence on span adjustment.

**Vibration effect :**

> ±0,25% of span for spans greater than 1/10 of URL.  
 Frequency 10 to 150Hz, acceleration 39,2m/sec<sup>2</sup> .

**Material fatigue :** Please consult Fuji Electric

**Dielectric strength:**

500V AC, 50/60Hz 1 min., between circuit and earth.

**Insulation resistance:**

More than 100MΩ/500V DC.

**Internal resistance for external field indicator:**

12 Ω maxi (connected to test terminal CK+ and CK-)

**Physical specifications**

**Electrical connections:**

1/2-14 NPT, Pg 13,5 or M20 x 1,5

**Process-wetted parts material:**

**Diaphragm:**  
 316L stainless steel, Hastelloy-C, Monel, Tantalum, Titanium or Zirconium  
**Flange face:**  
 316 stainless steel, Hastelloy-C, Monel, Tantalum, Titanium or Zirconium  
**Extension:**  
 316 stainless steel, Hastelloy-C  
 (Refer to "Code symbols")

**Non-wetted parts material:**

**Electronics housing:**  
 Low copper die-cast aluminum alloy finished with polyester coating (standard), or 316 stainless steel as specified.  
**Capillary:**  
 In case of 11th code "D, E, L, F, M, N, P", PVC armored stainless steel.  
 In case of 11th code "Q, R, S, T, V, W, X", stainless steel armored stainless steel.  
**Mounting flange:**  
 304 stainless steel or carbon steel, as specified  
**Fill fluid:**  
 Silicone oil (standard) or fluorinated oil  
**Mounting bracket:**  
 304 stainless steel

**Environmental protection:**

IEC IP67 and NEMA 6/6P

**Mounting:**

On 60.5mm (JIS 50A) pipe using mounting bracket, direct wall mounting

**Mass {weight}:**

Transmitter alone : 5kg without options.  
 Add: 0.5kg for mounting bracket  
 4.5kg for ss housing (option)  
 1.5kg per 50mm extension of diaphragm

**Diaphragm seal(s) :**

A comprehensive selection of seals can be chosen in accordance with the specific seal (see datasheet).

**Optional features**

**Indicator:**

A plug-in analog indicator (2.5% accuracy).  
 An optional 5-digit LCD meter with engineering unit is also available.

**Local configurator with LCD display:**

An optional 5 digits LCD meter with 3 push buttons can support items as using communication with FXW.

**Arrester:**

A built-in arrester protects the electronics from lightning surges.  
 Lightning surge immunity: 4kV (1.2 × 50µs)

**Optional tag plate:**

An extra stainless steel tag for customer tag data is wired to the transmitter.

**Vacuum service:**

Special silicone oil and filling procedure are applied.  
 See Fig.1

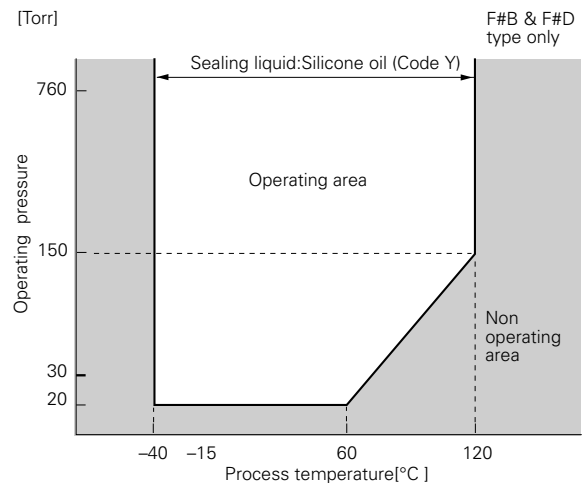

**Fig. 1 Relation between process temperature and operating pressure**

**ACCESSORIES**

**Hand-held communicator:**

(Model FXW, refer to Data Sheet No. EDS8-47)

# CODE SYMBOLS - FKB

1	2	3	4	5	6	7	8	9	10	11	12	13	DESCRIPTION
F	K	B				V	F				Y		Type Smart, 4-20 mA dc + Fuji/Hart® digital signal
													Conduit connection 1/2-14NPT Pg 13.5 M 20x 1.5
													Diaphragm seal rating PN 25 PN 20 - 150 Lbs PN 50 - 300 Lbs PN 40 PN 16 PN 100 - 600Lbs PN 150 - 900Lbs PN 250 - 1500Lbs PN 420 - 2500Lbs
													(*1) Spans (*2) 0 to 0.013/1.3 bar (*3) 0 to 0.05/5 bar (*4) 0 to 0.3/30 bar (*4) 0 to 1/100 bar (*4) 0 to 5/500 bar
													Indicator and arrester
													Indicator
													Arrester
													Initial setting
													None
													Analog, 0-100% linear scale
													Analog, Custom scale
													Analog, double scale
													None
													Analog, 0-100% linear scale
													Analog, Custom scale
													Analog, double scale
													Digital, 0-100%
													Digital, Custom scale
													Digital, 0-100%
													Digital, Custom scale
													Approvals for hazardous locations (consult FUJI for availability)
													None (Standard)
													ATEX - Flameproof enclosures (digit 4 = "R, T" & "W" only)
													ATEX - Intrinsic Safety
													(*8) FM - Explosion-Proof (Digit 4 = "T" only)
													CSA - Explosion-Proof (Digit 4 = "T" only)
													FM - Intrinsic Safety and Non Incendive
													CSA - Intrinsic Safety
													ATEX - Type "n" (Digit 9 = A, E, 1, 2, 3, 4, 5 & 6 only)
													IECEX - Type "n" (Digit 9 = A, E, 1, 2, 3, 4, 5 & 6 only)
													IECEX - Flameproof enclosures (Digit 4 = "M, P, R, T" & "W" only)
													IECEX - Intrinsic Safety
													CSA - Explosion-Proof & Intrinsic Safety combined approval (digit 4 = "T" only)
													ATEX - Flameproof enclosures & Intrinsic Safety combined approval (digit 4 = "R, T" & "W" only)
													IECEX - Flameproof enclosures & Intrinsic Safety combined approval (digit 4 = "R, T" & "W" only)
													FM - Explosion-Proof & Intrinsic Safety combined approval (digit 4 = "T" only)
													(*5) Mounting design (*5)
													Ambient temperature correction
													Capillary
													Rigid - long design
													Rigid - short design
													Capillary
													Rigid - long design
													Rigid - short design
													Cell flange design
													Operating pressure (bar)
													bolts/nuts
													SS tag plate
													SS parts
													SS hous. & mount bracket
													1 Y (*7) (*6) p ≤ 50 bar none None None
													2 Y (*7) (*6) p ≤ 50 bar none Yes None
													3 Y (*7) (*6) p ≤ 50 bar none None Yes
													4 Y (*7) (*6) p ≤ 50 bar none Yes Yes
													Y Y (*7) 50 < p ≤ 100 carbon steel None None
													B Y (*7) 50 < p ≤ 100 carbon steel Yes None
													C Y (*7) 50 < p ≤ 100 carbon steel None Yes
													E Y (*7) 50 < p ≤ 100 carbon steel Yes Yes
													A Y (*7) p ≤ 100 bar SS 316/SS 316 None None
													D Y (*7) p ≤ 100 bar SS 316/SS 316 Yes None
													F Y (*7) p ≤ 100 bar SS 316/SS 316 None Yes
													G Y (*7) p ≤ 100 bar SS 316/SS 316 Yes Yes
													P Y (*7) (*9) 100 < p ≤ 200 SS 630/SS 304 None None
													R Y (*7) (*9) 100 < p ≤ 200 SS 630/SS 304 Yes None
													S Y (*7) (*9) 100 < p ≤ 200 SS 630/SS 304 None Yes
													T Y (*7) (*9) 100 < p ≤ 200 SS 630/SS 304 Yes Yes

**Notes\* :**

- Turn down of 100:1 is possible, but should be used at the span greater than 1/10 of the maximum span for better performance.
- Consult FUJI for your application with the specific operating conditions
- For DN < 50 consult FUJI for your application with the specific operating conditions
- Flange rating according max. operating pressure - for DN < 50 flange size and / or PN > 150, consult FUJI
- Transmitter with capillary design has a standard mounting bracket - Rigid mounting design are always without mounting bracket
- If direct mounted seal design is required, bolts are necessary even when p < 50bar
- Standard fill fluid of measuring cells : silicone oil - Other fill fluids : upon request
- Code "D & V" FM approval only possible with electrical connection 1/2" NPT
- Our stainless steel bolts/nuts in SS630/304 are in conformity with the NACE requirements and must be used for NACE service.

CODE SYMBOLS - FKD

1	2	3	4	5	6	7	8	9	10	11	12	13	DESCRIPTION								
F	K	D		V	F					Y											
														(*5)	<b>Type</b> Differential pressure transmitter - Smart, 4-20 mADC + Fuji/Hart® digital signal						
															<b>Conduit connection</b> 1/2-14NPT Pg 13.5 M 20x 1.5						
															<b>Diaphragm seal rating</b> PN 25 PN 20 - 150 Lbs PN 50 - 300 Lbs PN 40 PN 16 PN 100 - 600Lbs PN 150 - 900 lbs PN 250 - 1500 lbs PN 420 - 2500 lbs						
															(*1)	<b>Spans</b>					
															(*2)	0 to 3,2/320 mbar					
															(*2)	0 to 0,013/1,3 bar					
																0 to 0,05/5 bar					
																0 to 0,3/30 bar					
																0 to 2/200 bar					
															<b>Indicator and arrester</b>						
																<b>Indicator</b>	<b>Arrester</b>	<b>Initial setting</b>			
																None	None	4-20mA DC + Hart ®/Fuji digital signal "SMART"			
																Analog, 0-100% linear scale	None				
																Analog, 0-100% √ scale	None				
																Analog, Custom scale	None				
																Analog, double scale	None				
																None	Yes				
																Analog, 0-100% linear scale	Yes				
																Analog, 0-100% √ scale	Yes				
																Analog, Custom scale	Yes				
																Analog, double scale	Yes				
																Digital, 0-100%	None				
																Digital, Custom scale	None				
																Digital, 0-100% √ scale	None				
																Digital, 0-100%	Yes				
																Digital, Custom scale	Yes				
																Digital, 0-100% √ scale	Yes				
																<b>Approvals for hazardous locations (consult FUJI for availability)</b>					
																None (Standard)					
																ATEX - Flameproof enclosures (digit 4 = "R, T" & "W" only)					
																ATEX - Intrinsic Safety					
																FM - Explosion-Proof (digit 4 = "T" only)					
																CSA - Explosion-Proof (digit 4 = "T" only)					
																FM - Intrinsic Safety and Non Incendive					
																CSA - Intrinsic Safety					
																ATEX - Type "n" (digit 9 = A, E, 1, 2, 3, 4, 5 & 6 only)					
																IECEX - Type "n" (digit 9 = A, E, 1, 2, 3, 4, 5 & 6 only)					
																IECEX - Flameproof enclosures (digit 4 = R, T" & "W" only)					
																IECEX - Intrinsic Safety					
																CSA - Explosion-Proof & Intrinsic Safety combined approval (digit 4 = "T" only)					
																ATEX - Flameproof enclosures & Intrinsic Safety combined approval (digit 4 = "R, T" & "W" only)					
																IECEX - Flameproof enclosures & Intrinsic Safety combined approval (digit 4 = "R, T" & "W" only)					
																FM - Explosion-Proof & Intrinsic Safety combined approval (digit 4 = "T" only)					
															(*5) (*6)	<b>Mounting design (*3)</b>		<b>Ambient temperature correction</b>			
																Capillary on HP side		Transmitter and diaphragm seal assembly			
																Capillary on HP & LP side		Transmitter and diaphragm seal assembly			
																Rigid short design on HP & capillary on LP side		Transmitter and diaphragm seal assembly			
																Capillary on HP side		Transmitter			
																Capillary on HP & LP side		Transmitter			
																<b>Cell flange design</b>		<b>SS parts</b>			
																Operating pressure (bar)	bolts/nuts	SS tag plate	SS housing		
																1 Y	(*4)	p ≤ 50 bar	None	None	None
																2 Y	(*4)	p ≤ 50 bar	None	Yes	None
																3 Y	(*4)	p ≤ 50 bar	None	None	Yes
																4 Y	(*4)	p ≤ 50 bar	None	Yes	Yes
																Y Y		50 < p ≤ 100	Carbon steel	None	None
																B Y		50 < p ≤ 100	Carbon steel	Yes	None
																C Y		50 < p ≤ 100	Carbon steel	None	Yes
																E Y		50 < p ≤ 100	Carbon steel	Yes	Yes
																A Y		p ≤ 100 bar	SS 316/SS 316	None	None
																D Y		p ≤ 100 bar	SS 316/SS 316	Yes	None
																F Y		p ≤ 100 bar	SS 316/SS 316	None	Yes
																G Y		p ≤ 100 bar	SS 316/SS 316	Yes	Yes
																P Y	(*8)	100 < p ≤ 200	SS 630/SS 304	None	None
																R Y	(*8)	100 < p ≤ 200	SS 630/SS 304	Yes	None
																S Y	(*8)	100 < p ≤ 200	SS 630/SS 304	None	Yes
																T Y	(*8)	100 < p ≤ 200	SS 630/SS 304	Yes	Yes

Notes\* :

- 1- Turn down of 100:1 is possible, but should be used at the span greater than 1/10 of the maximum span for better performance
- 2- For DN = 50 consult FUJI for your application with the specific operating conditions
- 3- Transmitter with capillary design has a standard mounting bracket
- 4- If direct mounted seal design is required, bolts are necessary even when p < 50bar
- 5- Standard fill fluid of measuring cells : silicone oil - Others fill fluids : upon request
- 6- Transmitter with different diaphragm seals or capillary lengths on HP and LP side must be temperature corrected.
- 7- Code "D & V" FM approval only possible with electrical connection 1/2" NPT.
- 8- Our stainless steel bolts/nuts in SS630/304 are in conformity with the NACE requirements and must be used for NACE service



# DIAPHRAGM SEAL(S)

S

Diaphragm seals are used to measure accurately liquid level, density on open and closed tanks, or flow measurement in pipes. The use of the diaphragm seal(s) avoid(s) that the measuring cell is directly in contact with the process. The welded seal construction assures excellent reliability in high temperature and high corrosive, viscous, sticking, crystallizable and abrasive process conditions.

## FEATURES

### 1- Construction

The diaphragm seals are mounted on differential, gauge and absolute pressure transmitters of FCX-All series. The seal can be rigid, (direct) mounted on the transmitter or with capillaries between the seal and the transmitter.

The construction is an all welded design without any gasket between the seal and the transmitter diaphragm and is filled with the suitable oil for your application.

### 2- Operating principle

The measuring pressure is applied on the diaphragm seal and transferred by the filling fluid through the capillary tube to the measuring cell of the pressure transmitter.

### 3- Parts materials

Wetted parts materials (diaphragm and gasket face) are in stainless steel, Tantalum, Hastelloy, Monel, Titanium, Zirconium, Nickel, depending on the application requirements. Other parts are in stainless steel: capillary tube, reduced volume flange, diaphragm seal body, direct mounting connection parts.

Standard filling fluid is silicone oil. Fluorinated oil, sanitary oil, high temperature oil and vacuum service filling are available through model selection.

### 4- Diaphragm seal types

According to the mounting and operating conditions different seal types can be useful :

Flush mounting design from DN40 to DN100.

Seals with extensions (50 to 200 mm).

Flanged, screwed or weld neck adaptors

Seals for sanitary applications according DIN, SMS or Tri-Clamp standards



## SPECIFICATIONS

### Functional specifications

#### Diaphragm seal application:

The seal(s) can be mounted direct or rigid on the transmitter (for example for liquid level measurement at the bottom of the tank) or capillary mounted to distance the measuring point away from the transmitter (for example in case of high process temperature). The rigid mounted seal can be assembled in a long design or in a short (compact) design according to the physical dimension requests of the customer (see outline dimensions drawings).

	Rigid mounting	Capillary mounting
F#B	short or long design	HP side
F#M	short or long design	HP side
F#D	see datasheet of level transmitter	HP and LP side HP side LP side

#### Capillary tube specifications :

Standard capillary lengths :

1,5 / 3 / 6 m (other upon request)

Inside diameter :

1 mm standard

2 mm for vacuum service, high process temperature applications, short response time requirements

Smallest bending radius of the capillary : 100 mm

#### Capillary tube sheald possibilities :

PVC sheald :

Temperature limit : -10 à 80°C

Stainless steel sheald :

Temperature limit : -40 à 400°C

#### Temperature limits :

Ambiant temperature : -40 to 85°C

Process temperature :

-40 to 150°C for rigid mounting,

-40 to 400°C for capillary design, and according the filling fluid limitations.



**Pressure limits :**

Working pressure :

Limited by the static pressure or the working pressure of the transmitter or by the nominal flange rating of the diaphragm seal (PN). (Please take the smallest of both)

Vacuum limit :

Depending of the limit of the transmitter and the filling fluid of the seal.

For a differential or gauge pressure transmitter the lowest vacuum is 20 Torr or 27 mbar abs.

Only the absolute pressure transmitter can be used till absolute zero (FKM).

For the utilization of vacuum service < 20 Torr (27 mbar abs.) the absolute pressure transmitter has to be used.

**Process temperature effect : (mbar/10°C)**

Seals	DN 50 / 2" SS diaphragm	DN 80 / 3" SS diaphragm	DN 80 / 3" Other diaph. materials.	DN 100 / 4" SS diaphragm	Adaptor SS diaphragm
for transmitters					
F#B/F#M	1.24	0.17	0.73	0.08	0.17
F#D	0.5	0.09	0.22	0.05	0.09

**Note : the indicated values are in mbar/10°C**

**Static pressure effect for ΔP transmitter with stainless steel diaphragms (F#D transmitter with DN80 and DN100 seals) :**

Zero shift :

± 0,2% of URL for flange rating, up to 40 bar or 300 lbs

Span shift :

- 0,2% <sup>+0,2%</sup>

- 0,1% of calibrated span for flange rating pressure

**Response time : (mean values)**

Oil filling	Code digit 7	Density at 25°C	Response time		
			0 to 320 mbar	0 to 640 mbar	0 to 1.3 bar
Std silicone oil	Y, G	0,934	0,15	0,08	0,037
Fluorinated oil	W,A,D	1,84	0,17	0,09	0,04
Oil for vacuum or high temperature	V, T	1,07	0,25	0,13	0,065

The indicated values are in seconds per meter of capillary length with internal tube diameter Ø 1 mm.

The indicated response time is based on a pressure change of 0 to 100% of the calibrated span at reference temperature of 20°C. The indicated values do not include the response time of the transmitter.

**Filling fluid of the diaphragm seals :**

Code digit 7	Designation	Temperature resistance (°C)		Density (25°C)
		P abs ≥ 1 bar	P abs < 1 bar	
Y	Silicone oil	-40 to 180	-40 to 120	0,934
W	Fluorinated oil	-20 to 200	-20 to 120	1,84
F	Sanitary fill fluids	-10 to 250	-10 to 120	0,92
V	Silicone oil		-10 to 200	0,934
T	Silicone oil	-20 to 400	-10 to 200	0,934

The indicated values and limits are indicated for the most common applications (standard filling fluids).

Please ask Fuji Electric for special applications indicating your temperature, pressure and vacuum conditions (vacuum and temperature can occur together).

Other filling fluids can be used for your applications.

**Performance specifications**

To calculate the total performance, both the transmitter and the diaphragm seals performances have to be added.

**Accuracy : (at reference conditions)**

The assembling of 1 or 2 diaphragm seals on a transmitter increases the accuracy error at reference conditions of 0,1% of the span.

**Ambient temperature effect :**

*Effect when transmitter alone is corrected*

Seal	DN 50 / 2" SS diaphr.	DN 80 / 3" SS diaphr.	DN 80 / 3" other diaph. materials	DN 100 / 4" SS diaphr.	Adaptor SS diaphr.
Transmitters					
F#B/F#M - gauge /abs pressure	2.03	0.11	0.22	0.04	0.11
capillary(m)	1.5	0.08	0.2	0.03	0.08
F#D - differential pressure	0.48	0.04	0.05	0.02	0.04
capillary (m)	0.32	0.03	0.07	0.01	0.03

**Note : the indicated values are in mbar/10°C for capillary length of 1m and internal capillary tube ø of 1 mm**

Effect when transmitter and the seal assembly is corrected

The zero drift due to ambient temperature changes are improved (between 2 and 5 times) by an additional temperature correction operation of the complete transmitter unit (transmitter and seals) (see code B,C,L,M digit 11 of the codification F#B, F#D, F#M)

A thermal isolation or a heating of the capillaries minimises the ambient temperature effect.

CODE SYMBOLS - S

1	2	3	4	5	6	7	8	DESCRIPTION
S								Flanged axial diaphragm seal connection
A								Flanged radial diaphragm seal connection - Not possible with rigid mounting design digit 6 : code R
R								Wafer type - Not possible with rigid mounting design digit 6 : code R
W								(*)1 Flanges RF (Flange size and rating)
	4							ANSI-150LB 3"-ISO PN 20 DN 80
	5							ANSI-150LB 4"-ISO PN 20 DN 100
	6							ANSI-300LB 3"-ISO PN 50 DN 80
	7							ANSI-300LB 4"-ISO PN 50 DN 100
	8							DIN PN40 DN80
	9							DIN PN16 DN100
H								(*)2 ANSI-150LB 2"-ISO PN 20 DN 50
J								(*)2 ANSI-300LB 2"-ISO PN 50 DN 50
G								(*)2 DIN PN40 DN50
U								PN 25 / DN 50 - coupling nut DIN 11851 design material code "V" only
V								PN 40 / DN 50 - coupling nut SMS material code "V" only
W								PN 40 / DN 50 - seal only Clamp material code "V" only
X								No dead volume Sanitary material code "V" only
A								(*)3 Flange adaptor PN 40 DN 25 material code "V" - others UR
B								(*)3 Flange adaptor ISO PN 20 DN 25 (1"-150 ANSI) material code "V" - others UR
C								(*)3 Flange adaptor ISO PN 50 DN 25 (1"- 300 ANSI) material code "V" - others UR
D								(*)3 Flange adaptor PN 40 DN 40 material code "V" - others UR
E								(*)3 Flange adaptor ISO PN 20 DN 40 (1"1/2 - 150 ANSI) material code "V" - others UR
F								(*)3 Flange adaptor ISO PN 50 DN 40 (1"1/2 - 300 ANSI) material code "V" - others UR
S								(*)3 Screwed 1/2 NPTE material code "V" - others UR
T								(*)3 To be welded (pipe 2"1/2) material code "V" - others UR
								<b>Diaphragm seal material</b>
V								Diaphragm Flange raised face Flange
H								(*)4 SS 316 L SS 316 L SS 316 L
B								(*)9 Hastelloy-C Hastelloy-C SS 316 L
T								(*)9 Monel Monel SS 316 L
P								(*)9 Tantalum Tantalum SS 316 L
R								(*)9 Titanium Titanium SS 316 L
C								(*)9 Zirconium Zirconium SS 316 L
F								(*)9 SS 316 L + gold coat SS 316 L SS 316 L
								(*)9 (*)5 SS 316L + FEP lining SS 316 L + FEP lining SS 316 L
								<b>Diaphragm seal design</b>
Y								Flush mounting
A								(*)6 Diaphragm extension 50 mm
B								(*)6 Diaphragm extension 100 mm material code "V" - digit 4
C								(*)6 Diaphragm extension 150 mm
D								(*)6 Diaphragm extension 200 mm
E								(*)6 Diaphragm extension 50 mm
F								(*)6 Diaphragm extension 100 mm material code "H" - digit 4
G								(*)6 Diaphragm extension 150 mm
H								(*)6 Diaphragm extension 200 mm
J								(*)6 Diaphragm extension 50 mm
K								(*)6 Diaphragm extension 100 mm material code "B" - digit 4
L								(*)6 Diaphragm extension 150 mm
M								(*)6 Diaphragm extension 200 mm
P								(*)6 Diaphragm extension 50 mm
R								(*)6 Diaphragm extension 100 mm material code "T" - digit 4
S								(*)6 Diaphragm extension 150 mm
T								(*)6 Diaphragm extension 200 mm
								<b>Transmission diaphragm seal to measuring cell</b>
A								Mounting design Capillary length Capillary design
B								Capillary 1,5 m PVC protection
C								Capillary 3 m PVC protection
D								Capillary 6 m PVC protection
G								(*)7 Capillary Upon request PVC protection
H								(*)7 Capillary 1,5 m SS sheald (*10)
K								(*)7 Capillary 3 m SS sheald (*10)
L								(*)7 Capillary 6 m SS sheald (*10)
R								(*)7 Capillary Upon request SS sheald (*10)
								rigid design - not possible with digit 2 = R, W max. process temperature : 150°C
								<b>Special applications and fill fluid for the diaphragm seal only</b>
Y								Treatment Fill fluid
W								None (standard) Silicone oil
F								None (standard) Fluorinated oil
D								None (standard) Sanitary fill fluid
G								Chlorine service Fluorinated oil
A								Degreasing Silicone oil
N								Oxygen service Fluorinated oil material code "V" only
V								NACE Silicone oil
T								(*)8 Vacuum - max temp 200°C Silicone oil
								(*)8 Very high temp (-20 to 400°C) - no vacuum
								<b>Special options or design</b>
								(*)10 special, no code available

Notes :

- 1\* Different flange machinings (recess, groove, ...) upon request, standard flange machining = stock finish; except for digit 4 - material code H, B, T, P, R, F = smooth finish
- 2\* Only available with span higher than : 0 to 0,5/5 bar - max process temperature : 150°C - or ask FUJI with operating conditions
- 3\* Axial diaphragm seal connection - no extension possible
- 4\* SS316L for DN 50, 80 & 100 & flange adaptors
- 5\* Not possible with digit 7 : V, H, T
- 6\* All wetted parts in the same material (diaphragm, extension, flange gasket area)
  - Other flange designs are available
  - only available with flange size digit 3 code 4, 5, 6, 7, 8, 9, H, J, G
- 7\* Recommended for Vacuum or High Temperature applications T > 120°C - (Capillary internal diameter = 2mm)
- 8\* Consult FUJI for your application with the specific operating conditions
- 9\* Add values for material options are for = DN 80 PN40/ANSI-150LB 3" flange rate, DN 100 or 4" add values are available upon request
- 10\* When no code can be found in the current code symbols, place \* in concerned code digit(s) & add \* in 8 th digit
- 11\* Max process temperature 150 °C

# Outline dimensions for rigid mounted diaphragm seal on a gauge or an absolute pressure transmitter (unit:mm)

Dimensions of seals - Refer to page 18, 19 and 20

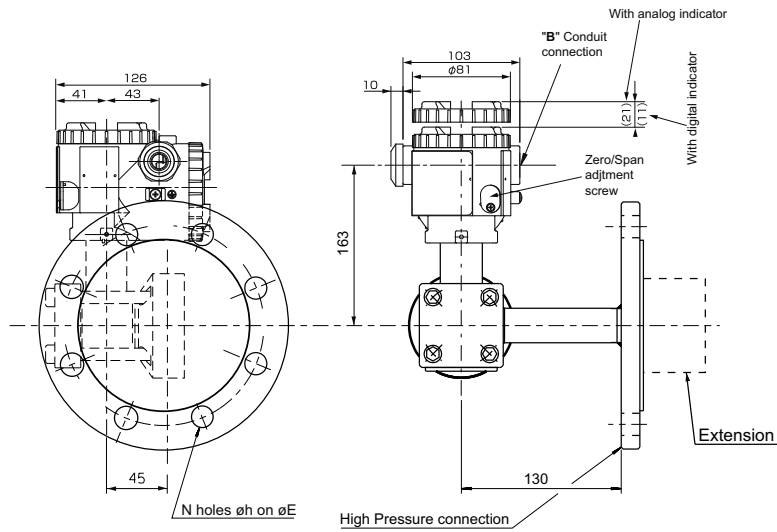

Short mounting design

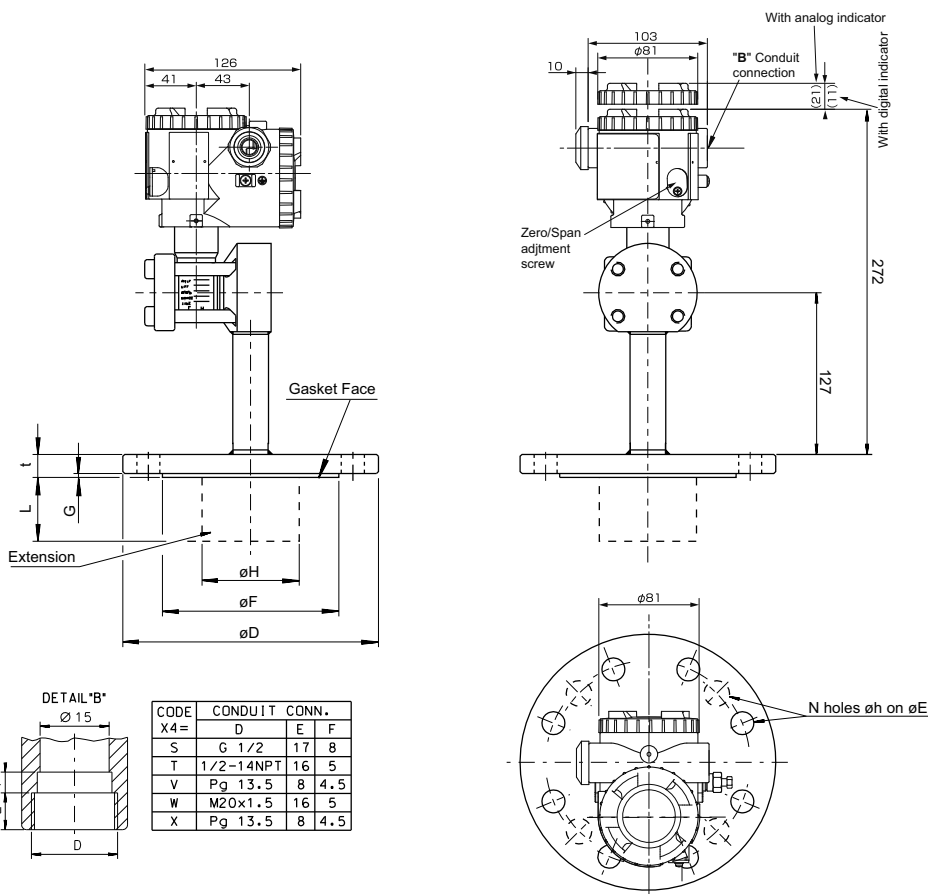
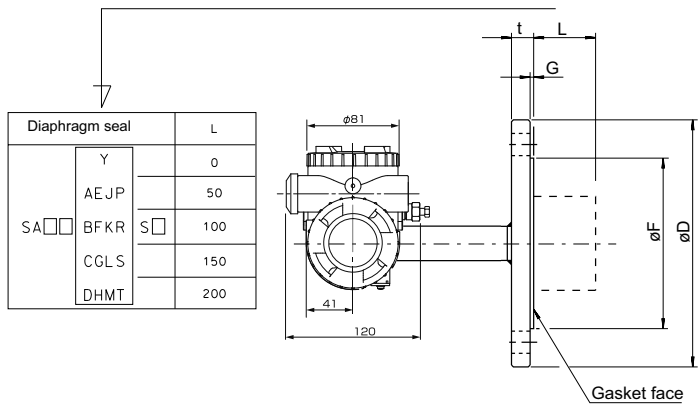

Long mounting design

**Outline dimensions for capillary mounted diaphragm seal(s) on a differential pressure transmitter (units:mm)**

Dimensions of seals - Refer to page 18, 19 and 20

**For PN≤50bar : reduced volume flanges are welded on the measuring cell**

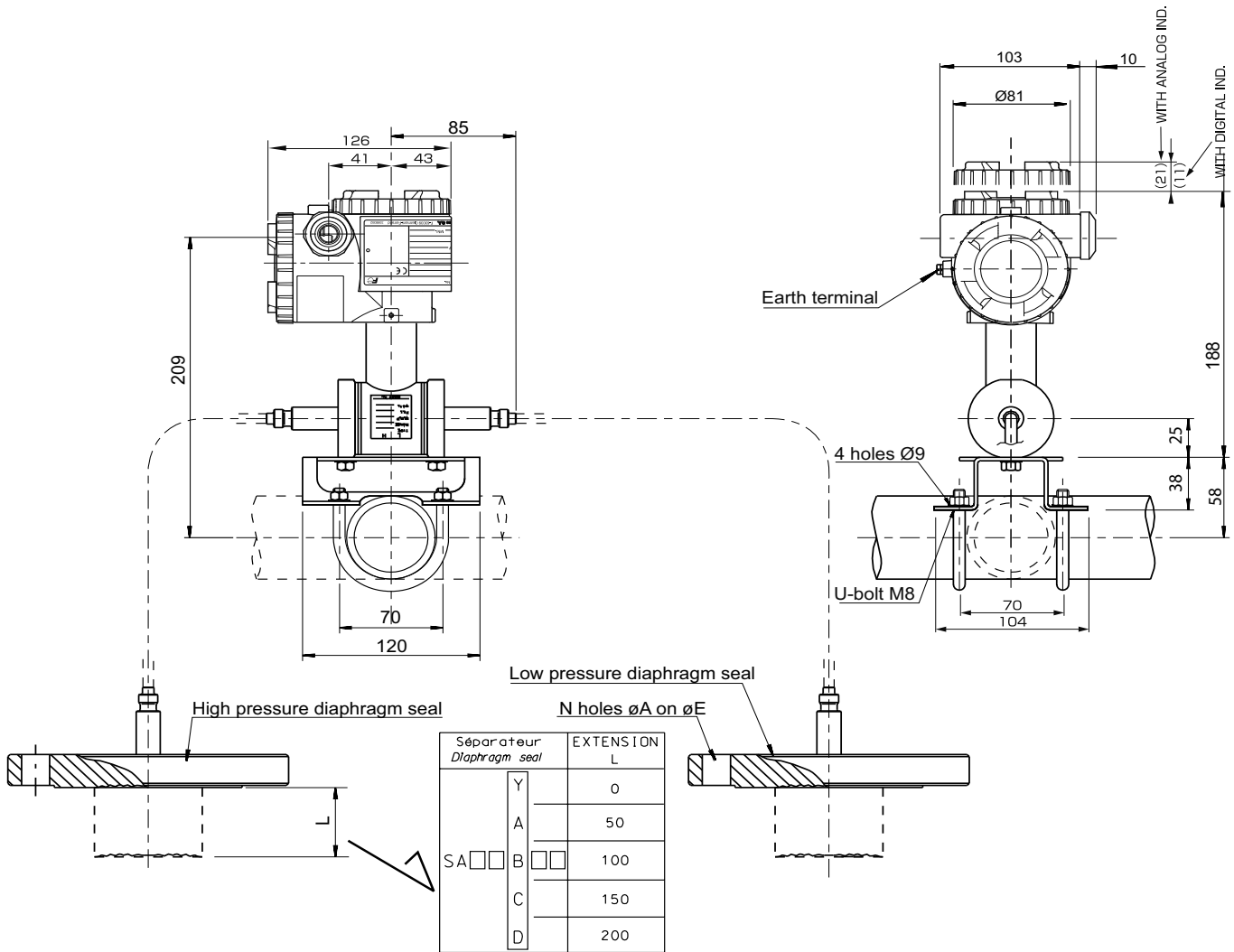

**For PN>50bar : reduced volume flanges are welded and bolted on the measuring cell**

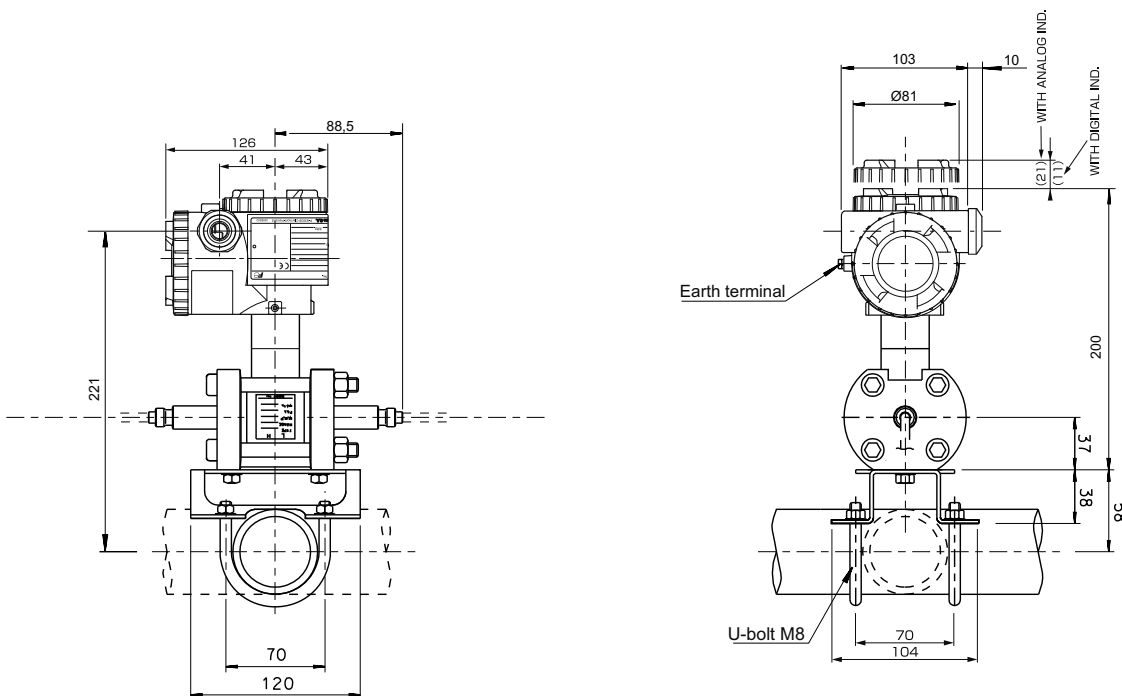

# Outline dimensions for capillary mounted diaphragm seal(s) on a gauge or an absolute pressure transmitter (units:mm)

Dimensions of seals - Refer to page 18, 19 and 20

**For PN≤50bar : reduced volume flanges are welded on the measuring cell**

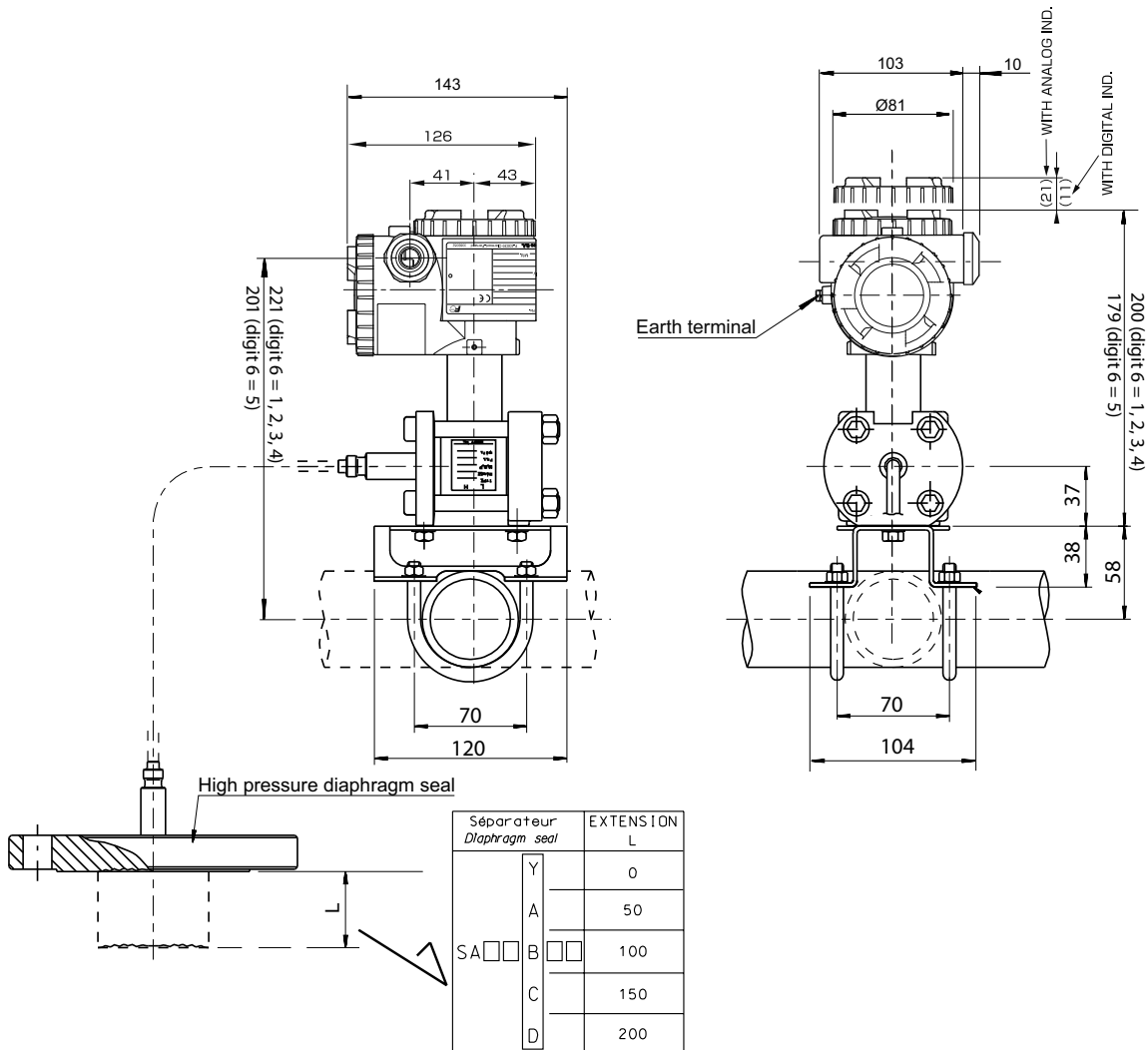

**For PN>50bar : reduced volume flanges are welded and bolted on the measuring cell**

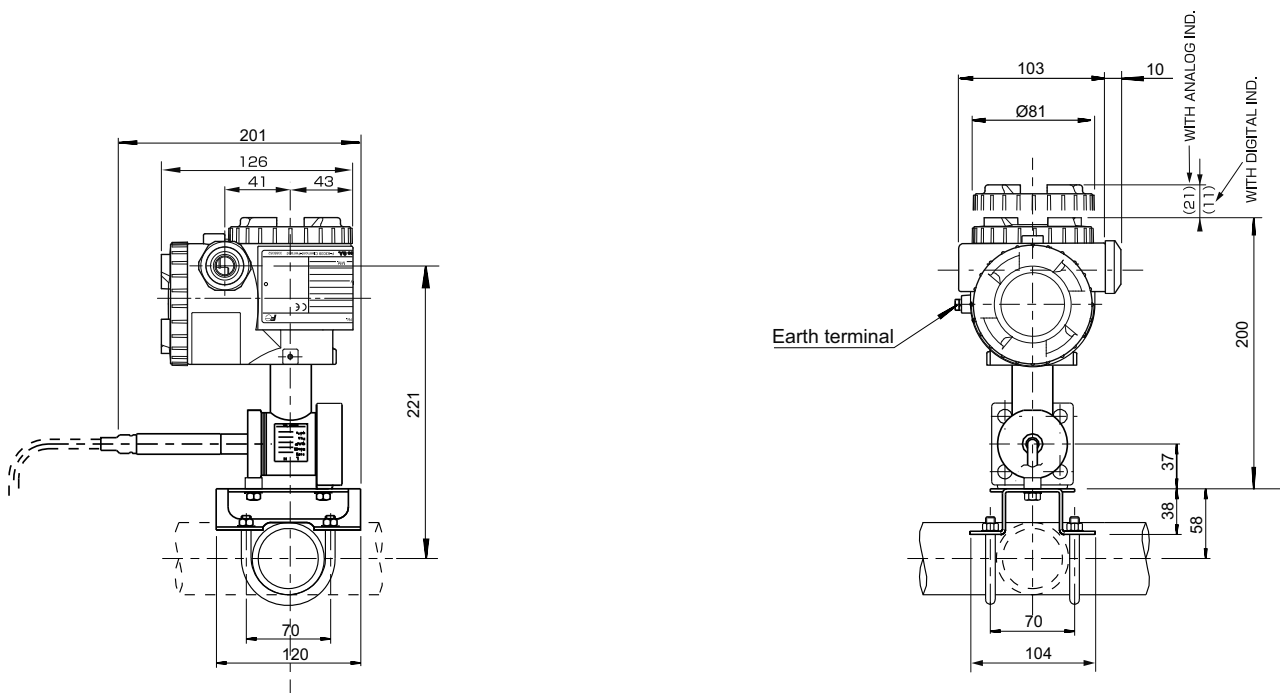

**Outline dimensions of the standard diaphragm seals - Flush and extension**

(units : mm)

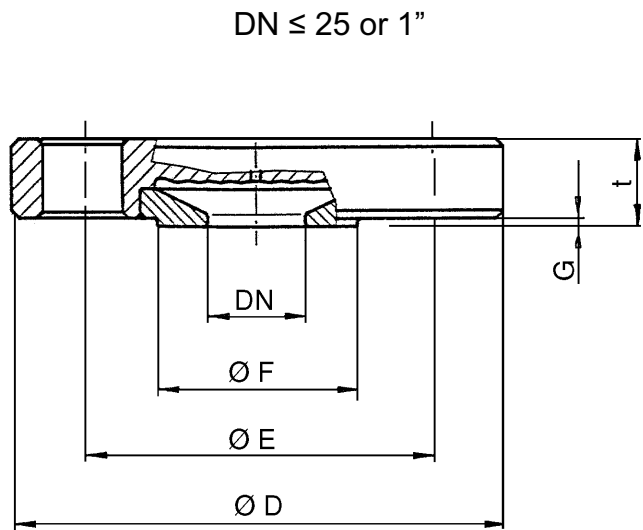
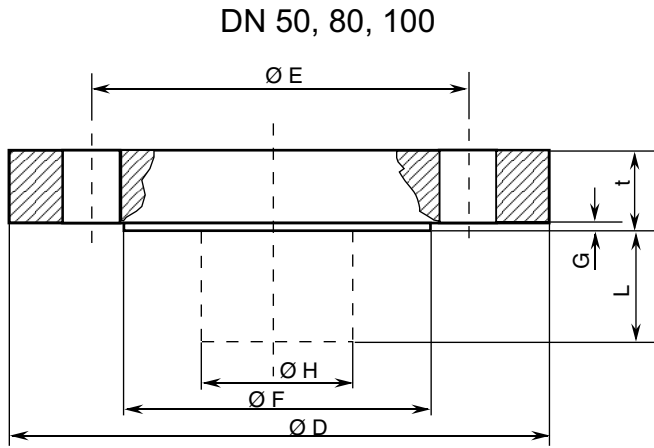

FLANGE DIMENSIONS ACCORDING DIN 2501 ET B16.5

DIN / ISO		ANSI		ØD	ØE	ØF	G	ØH	t	N x Øh
PN	DN	NP	NW							
40	15			95	65	45	2		22	4 x 14
40	20			105	75	58	2		22	4 x 14
40	25			115	85	68	2		22	4 x 14
40	50			165	125	102	3	48	20	4 x 18
40	80			200	160	138	3	73	20	8 x 18
16	100			220	180	158	3	96	20	8 x 18
20	15	150 lbs	1/2"	95	60,5	35	2		22	4 x 16
20	20	150 lbs	3/4"	100	70	43	2		22	4 x 16
20	25	150 lbs	1"	110	79,5	51	2		22	4 x 16
50	15	300 lbs	1/2"	95	66,5	35	2		22	4 x 16
50	20	300 lbs	3/4"	120	82,5	43	2		22	4 x 20
50	25	300 lbs	1"	125	89	51	2		22	4 x 20
20	50	150 lbs	2"	150	120,5	92	1,6	48	20	4 x 20
20	80	150 lbs	3"	190	152,5	127	1,6	73	24	4 x 20
20	100	150 lbs	4"	230	190,5	158	1,6	96	24	8 x 20
50	50	300 lbs	2"	165	127	92	1,6	48	22,5	8 x 20
50	80	300 lbs	3"	210	168,5	127	1,6	73	29	8 x 22
50	100	300 lbs	4"	255	200	158	1,6	96	32	8 x 22

**CONNECTION DIAGRAM**

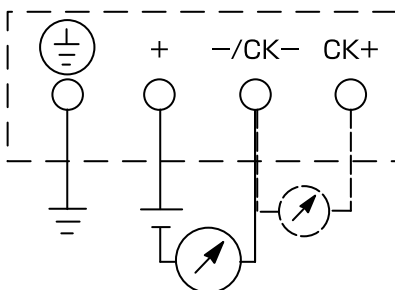

# Outline dimensions of sanitary diaphragm (units : mm)

The seals for the sanitary and pharmaceutical applications are available DIN, SMS and Tri Clamp standards

## Seals according DIN 11851 and SMS standard

2 different designs exists for DIN 11851 and SMS : ( $d_M$  = diamètre actif de la membrane)

**Coupling nut design**

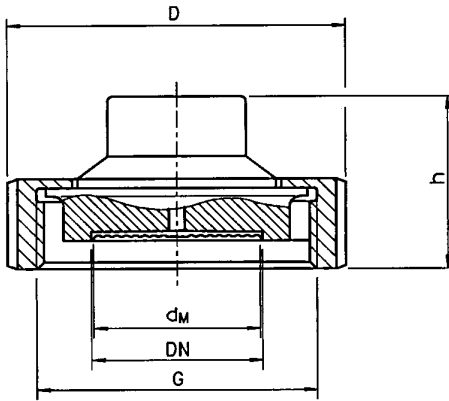

**DIN 11851**

DN	PN (Max)	D	h	$d_M$	G
25	40	63	36	25	Rd 52 x 1/6
32	40	70	36	32	Rd 58 x 1/6
40	40	78	36	40	Rd 65 x 1/6
50	40	112	36	52	Rd 78 x 1/6
65	40	112	36	65	Rd 95 x 1/6
80	40	127	36	76	Rd110 x 1/4

**Male thread design**

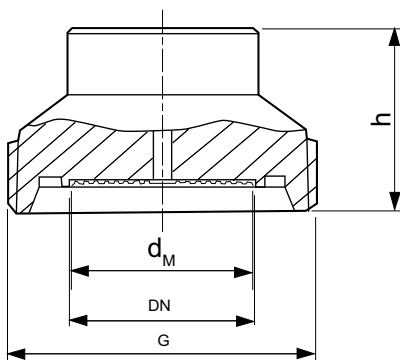

**SMS**

DN	PN (Max)	D	h	$d_M$	G
25	40	51	38	25	Rd 40 x 1/6
32	40	60	38	32	Rd 48 x 1/6
38	40	74	38	40	Rd 60 x 1/6
51	40	84	38	52	Rd 70 x 1/6
63.5	40	100	38	65	Rd 85 x 1/6
76	40	114	38	76	Rd 98 x 1/4

**Tri Clamp design**

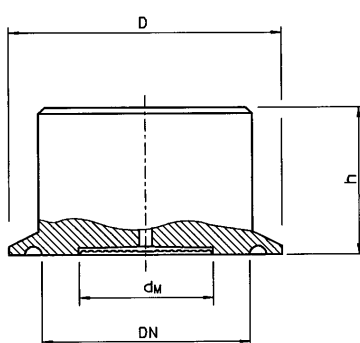

DN	PN (Max)	D	h	$d_M$
1"1/2	40	50,5	35	32
2"	40	64	35	40
2"1/2	40	77,5	35	50
3"38	40	91	35	65

**Dead volume seal**

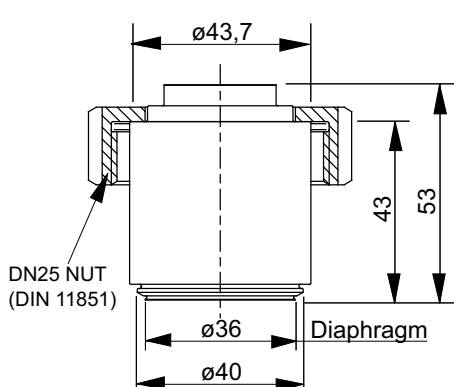

**Outline dimensions of diaphragm seals with adaptors (units : mm)**

**Flange adaptor**

**Screwed adaptor**

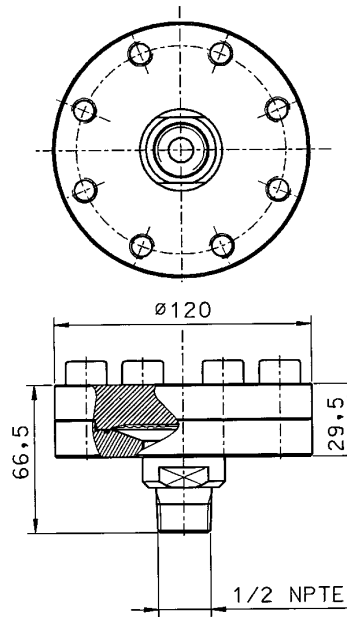
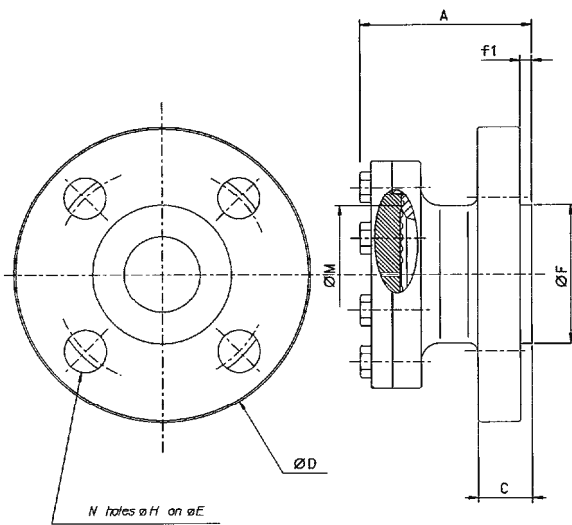

FLANGES DIMENSIONS												
DIN		ANSI		ØD	ØE	N		ØF	Cmin	f1	A	ØM
PN	DN	Pe	DN			N	ØH					
40	25			115	85	4	14	68	17	2	83	72,2
20	25	150	1"	108	79,5	4	15,8	50,8	16	1,6	81	72,2
50	25	300	1"	124	88,9	4	19	50,8	17,5	1,6	86	72,2
40	40			150	110	4	18	88	17	3	85	72,2
20	40	150	1 1/2"	127	98,4	4	15,8	73	17,5	1,6	85	72,2
50	40	300	1 1/2"	156	114,3	4	22,2	20,6	73	1,6	91	72,2

The product conforms to the requirements of the Electro-magnetic compatibility Directive 89/336/EEC as detailed within the technical construction file number TN513035. The applicable standards used to demonstrate compliance are :

**EMI (Emission) EN61326 : 1997**

Class A (std for Industrial Location)

Frequency range MHz	Limits	Reference Standard
3 to 230	40dB (µV/m) quasi peak measured at 10m distance	CISPR16-1 and CISPR16-2
230 to 1000	47dB (µV/m) quasi peak, measured at 10m distance	

Note) Definition of performance criteria

- A** : During testing, normal performance within the specification limits
- B** : During testing, temporary degradation, or loss of function or performance which is self-recovering.

**EMS (Immunity) EN61326 : 1997**

Annex A (standard for Industrial Location)

Phenomenon	Test value	Basic Standard	Performance criteria
Electrostatic discharge	4kV (Contact) 8kV (Air)	IEC61000-4-2	B
Electromagnetic field	80 to 1000MHz 10V/m 80%AM (1kHz)	IEC61000-4-3	A
Rated power frequency magnetic field	30A/m 50Hz	IEC61000-4-8	A
Burst	2kV 5kHz	IEC61000-4-4	B
Surge	1.2µs/50µs 1kV (Line to line) 2kV (line to ground)	IEC61000-4-5	B
Conducted RF	0.15 to 80MHz 3V , 80%AM (1kHz)	IEC61000-4-6	A

**Fuji Electric France S.A.**

46, Rue Georges Besse - Z I du Brézet

63 039 Clermont-Ferrand cedex 2 — FRANCE

France : Tél. 04 73 98 26 98 - Fax 04 73 98 26 99

International : Tél. (33) 4 7398 2698 - Fax. (33) 4 7398 2699

E-mail : sales.dpt@fujielectric.fr